



High-Output Product Development - Faster, Better, More Cost-Effective -

Chemspeed Technologies AG

25th February 2010

Dr. Michael Schneider
Senior VP Business Development

You certainly face challenges like ...

Bans on commonly used additives / raw materials?

Additives / raw materials with lack of biodegradability?

Facing the consequences of REACH?

Never really questioned the composition and process of your formulations?

Are you also developing products like ...?

Knorr präsentiert eine neue Generation von Bouillon...

Eine Bouillon, die schmeckt wie selbstgemacht

Für das KNORR BOUILLON TÖPFLI werden nur feinste Zutaten verwendet, schonend gekocht und direkt ins Töpflchen gegeben. Deshalb schmeckt die Bouillon wie selbstgemacht.

Rezepte



Ihr Urteil

Gewinnen Sie 1 von 5 Abendessen für 2 Personen bei René Schudel.



"Wenn früher alles besser war, schmeckt diese Bouillon wie früher"

Erfahren Sie mehr über **René Schudel, Gastronom und Koch** »



Knorr

- ✓ Ohne geschmacksverstärkende Zusatzstoffe
- ✓ Ohne Konservierungsmittel laut Gesetz

KNORR
Bouillon Töpflchen

New Generation of Bouillon

- ✓ Without Taste Enhancers
- ✓ Without Preservatives

You certainly face challenges like ...

Bans on commonly used additives / raw materials?

Additives / raw materials with lack of biodegradability?

Facing the consequences of REACH?

Never really questioned the composition and process of your formulations?

Are you also developing products like ...?

**Why not developing and selling products
“without” additives?**

Isn't less chemistry better chemistry?

How to cope with this?

Flavor microencapsulation workflow example

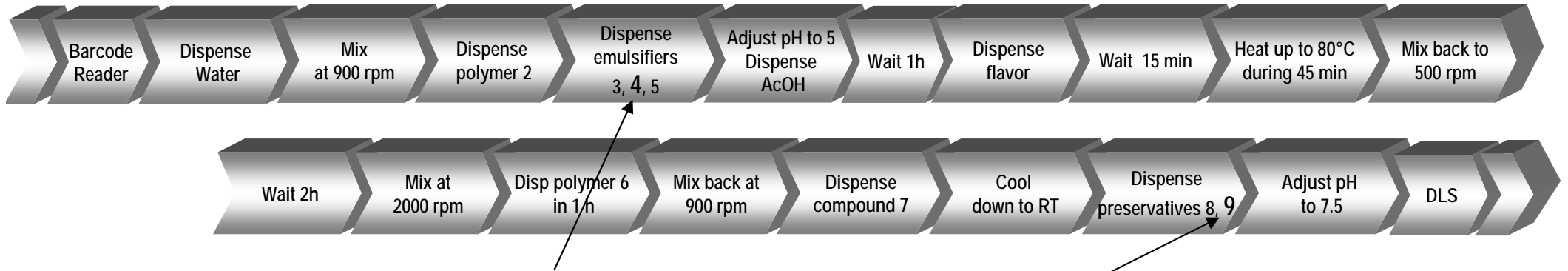

Objective: eliminate emulsifier 4 and preservative 9

Consequence: hundreds of reformulations

However NOT by doing ONE-BY-ONE BUT by doing MANY IN PARALLEL

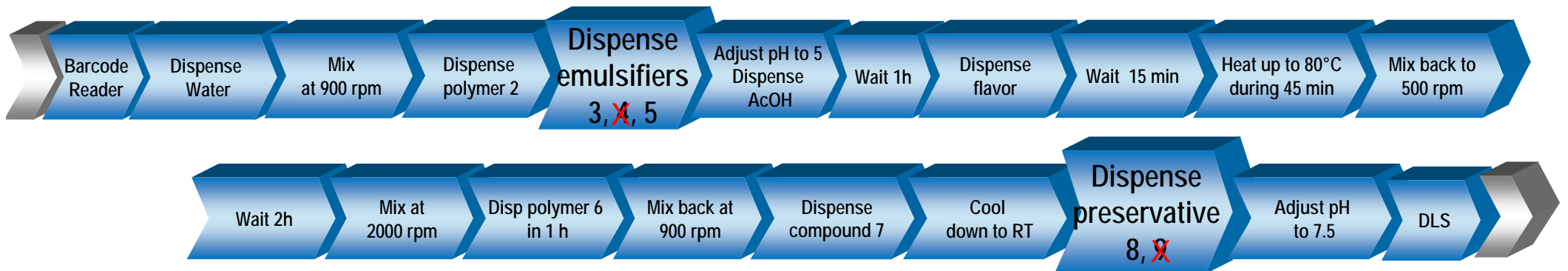

Snaglist of other fully automated consumer good formulations

- ✓ **Microencapsulation of milk fat**
- ✓ **Pesticide analysis in food (QuEChERS)**
- ✓ **Sun screen products**
- ✓ **Skin care products**
- ✓ **Hair colorants**
- ✓ **Hair gel**
- ✓ **Hair styling cream**
- ✓ **Shampoo**
- ✓ **Oral care products**
- ✓ **Hair conditioner**
- ✓ **Liquid and solid detergents**
- ✓ **... and more**

FORMAX – fully automated formulation workstation

- ✓ Faster
- ✓ Better
- ✓ More Cost-Effective



FORMAX

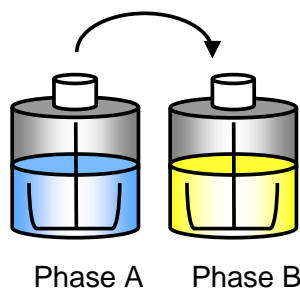

**High-Precision
Formulation
Vessel**

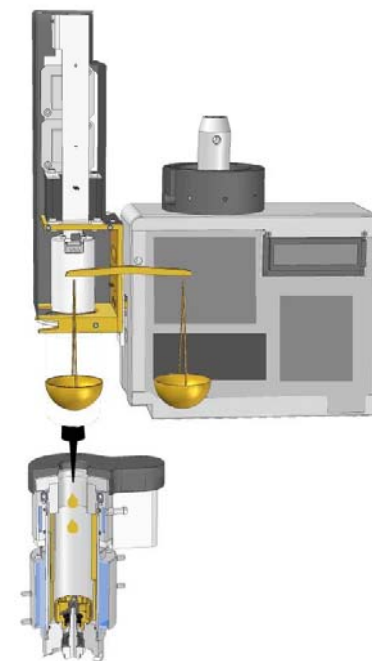

**Overhead Gravimetric
Solid, (viscous) Liquid,
Paste, Wax Dispensing
WHILE
Stirring, Scraping,
Heating, Refluxing,
Cooling**

High Output Product Development

Chemspeed's vision on hardware and software integration

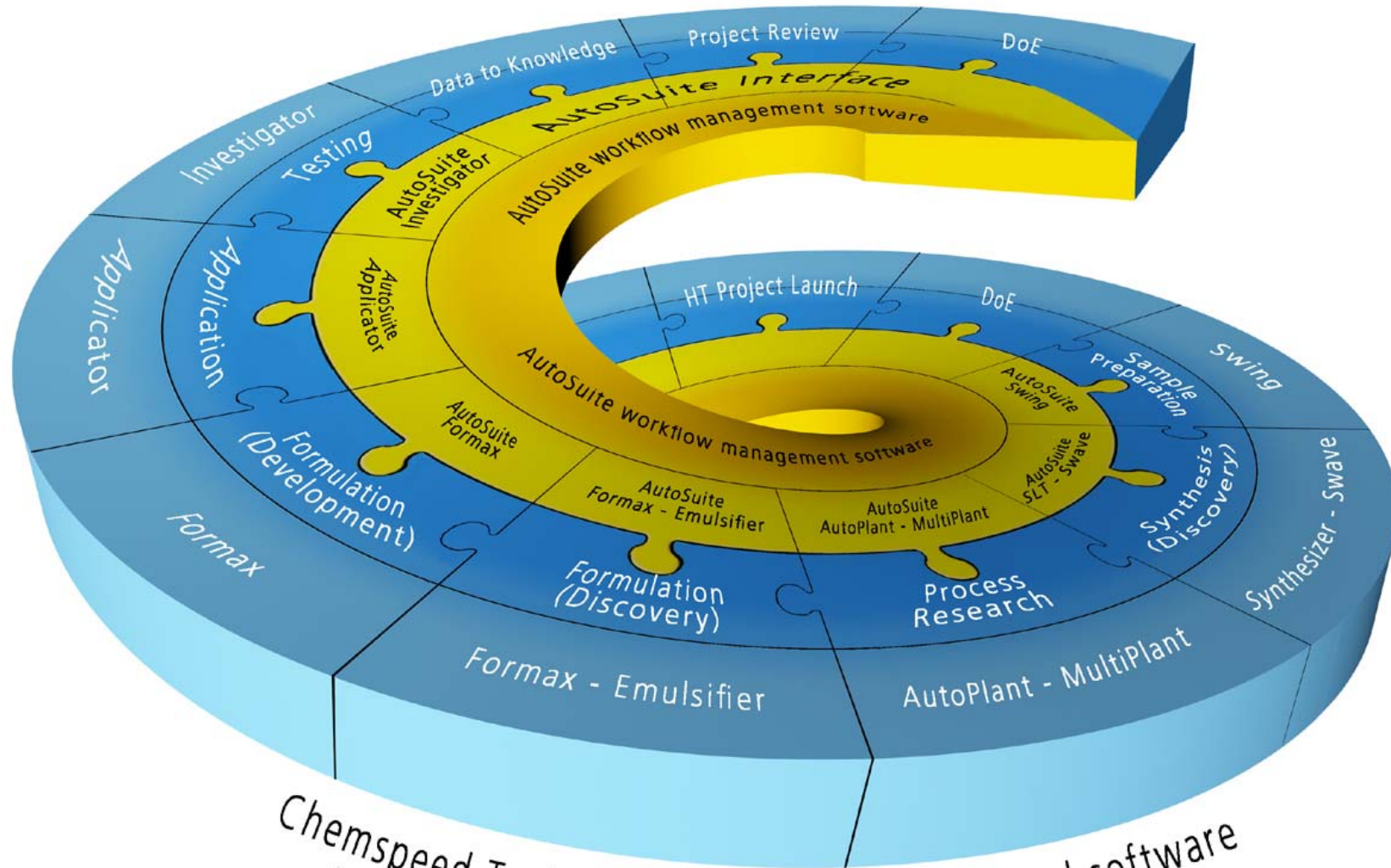

Chemspeed Technologies offers hardware and software for every step in the product development cycle

(Flexibility and Modularity)³

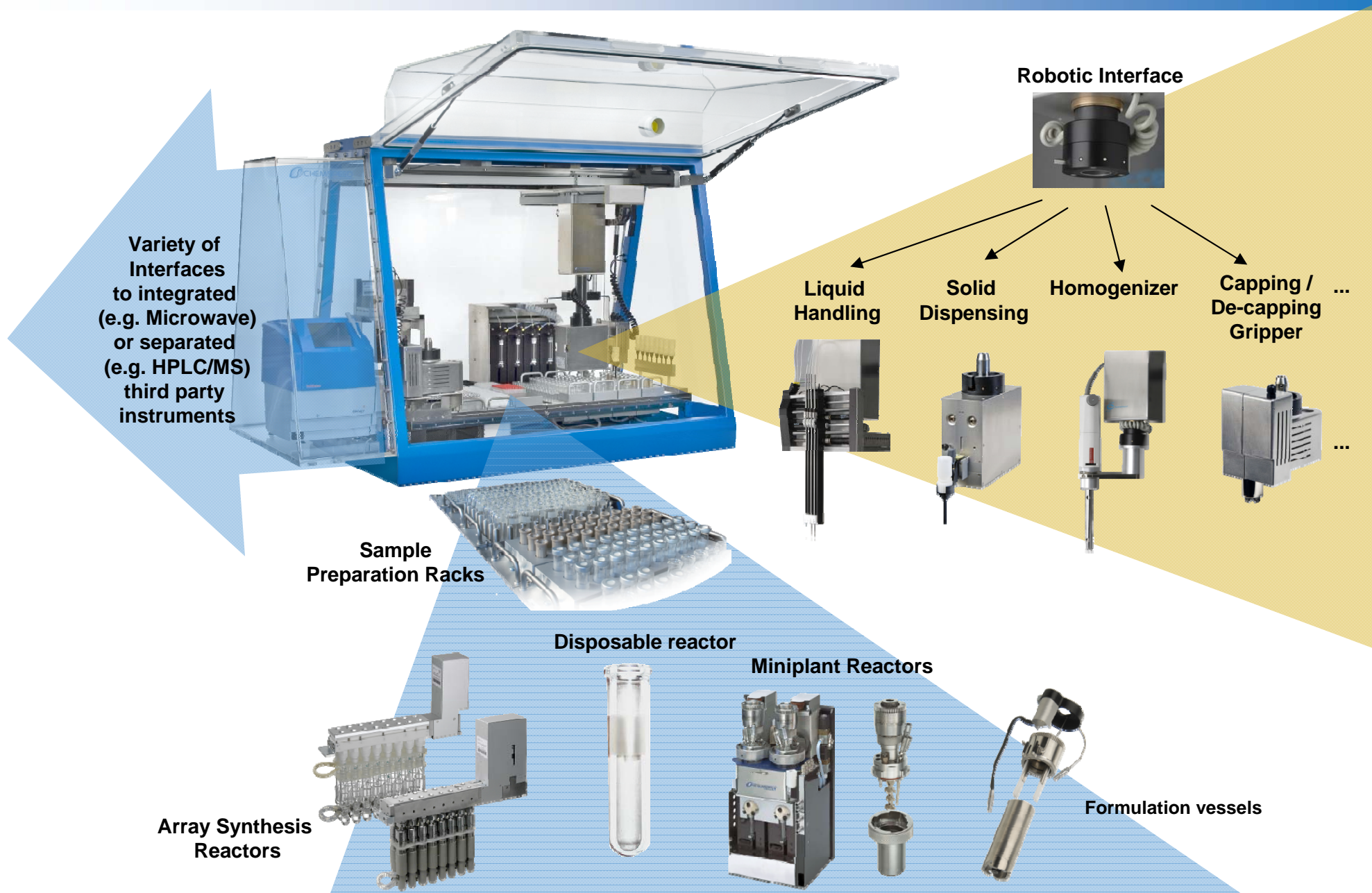

Seeing & doing is believing

Visit us in order to see our unique solutions in action!

